

■ External Dimensions (Throat dimensions=DXE)

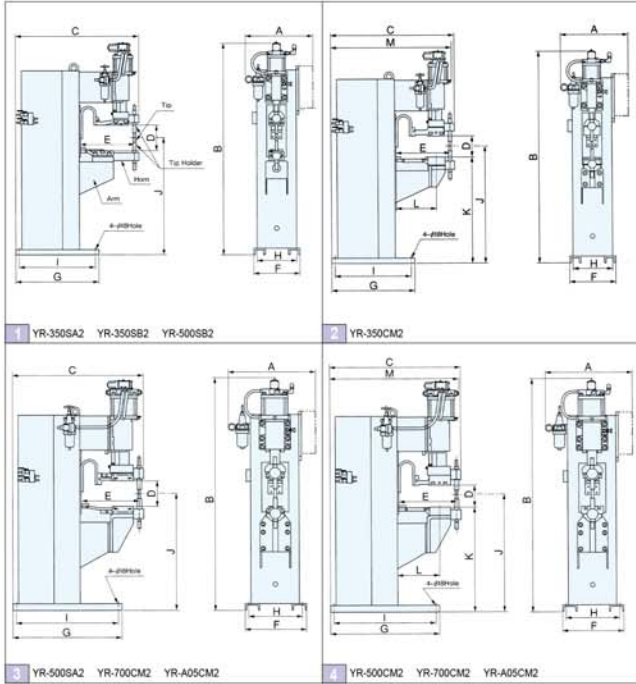

■ External Dimensions (unit: mm)

	A	B	C	D	E	F	G	H	I	J	K	L	M
YR-350SA2, YR-350SB2, YR-500SB2	530	1630	1100	200	600	340	750	265	700	300	—	—	—
YR-350CM2	530	1630	900	170	400	340	600	265	560	300	815	300	—
YR-500SA2	580	1780	1150	200	600	440	800	390	750	300	—	—	—
YR-500CM2	580	1780	880	165	425	440	800	390	750	300	812	300	—
YR-700SA2	580	1780	1150	200	600	440	800	390	750	300	—	—	—
YR-A05SA2	634	1780	1017	200	425	440	800	390	750	300	—	—	—
YR-700CM2	650	1780	880	165	425	440	800	390	750	300	—	300	—
YR-A05CM2	600	1780	1017	185	428	440	800	390	750	300	812	300	1005

Panasonic

A.C. Resistance Welder & Micro-Computer Controlled Resistance Welder Timer



Micro-Computer Controlled Timer Panatech YF-0201Z5



Standard IC Controlled Timer YF-0701D



Panasonic

With outstanding Panasonic Micro-Computer Controlled Timers, Panasonic A.C. Resistance Welders provide excellent and precise welding controls. As a result, Panasonic welders yield exceptional welding performance.

Panasonic

Panasonic

Panasonic Welding Systems (Tangshan) Co., Ltd.
 Tel: (0315) 3206066-3206069 Fax: (0315) 3206018 3206070
 Service hotline: (0315) 3206016 8008035816
 Technique consulting hotline: (0315) 3206012
 Website: <http://www.panasonic.cn>
 E-mail: sales@tsm.com.cn
The color is subject to be different to the real product. The specifications are subject to change without notice.
 Advertiser: Panasonic Welding Systems (Tangshan) Co., Ltd. Address: No.9 Qinghai Road, Tangshan New & Hi-tech Development Zone, Tangshan, Hebei, China.
 Printed by Tangshan Huapeng Printing Co., Ltd. Address: No.124 Huayu Road, Tangshan New & Hi-tech Development Zone, Tangshan, Hebei, China.

Printed in November 2011

Design No. 02108

A perfect combination for any welding job.

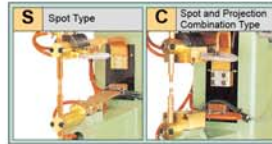

1. Adjustable speed head
The ascending and descending speed of the press head can be freely and continuously adjusted. The shock, impact, and noise of the electrode impacting the work piece can be precisely controlled.

2. Designed for fast response and quick motion
The stroke bearing in the guide unit is designed for less friction. The solenoid valve is directly coupled to the cylinder. This gives a fast response and a very high action speed.

3. Adjustable lower and upper horns extend and contract to conform to the work piece requirements for high flexibility.

The lower horn can be moved back and forth depending on the shape of the object to be welded.
(Applicable models: 150SA2, 350SA2, 350SA2, SM2, 350SB2, 500SB2)
The horns are round on both top and bottom so that it can be rotated.

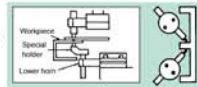

4. Water-saving type forced circulation system

The cooling water is circulated by forced circulation system, and is not discarded.
The flow rate of cooling water is notably decreased.
(Example: In the case of 35kVA, it is decreased from 6 liters/min to 2 liters/min.)

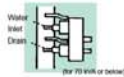

5. Press cylinder requires no oiling.
With this design, exhaust air does not contain oil mist allowing for improved environmental safety and cleanliness.
Maintenance is reduced by elimination of oil reservoir refilling requirements.

6. Welder interlock
Two units can be easily interlocked by external wiring. Simultaneous activation is prohibited. Tish minimizes the facility line voltage power demand and fluctuations.

7. Easy-to-mount timer
For electric connection of timer and welding power supply, a connector is used, and for mounting timer on the machine main body, three bolts are used.
(Applicable up to 70 kVA.)

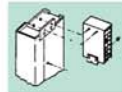

8. Upper arm insulation
To prevent shortcircuit accident of the insulated part when the welding jig is mounted on the lower arm.

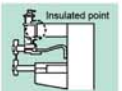

9. Thyristor (S.C.R) control of output.
Welding maintenance is reduced and reliability is improved.

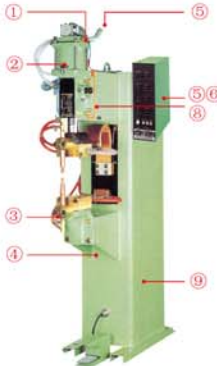

Wide selection range for various models, output amperages and timers.

MODELS AND RATINGS

	Model	Nominal Power	Speed	Welding Current (Max.)	Max. Input	Duty Cycle	Throat Dimensions	Electrode Pressure	Electrode Stroke	Cooling water	Weight	Welding Capacity (Steel plate B class)	
													kVA
S	YR-155SA2	15	50	12000	35	9.1	155x200	150	20	2	210	—	
	YR-350SA2	35	50	14000	59	11.5	185x190	250	20	2	210	—	
	YR-350SA2	35	50	13000	59	17.6	200x600	500	20-60	2	255	2.3t x 2.3t	
	YR-350SB2	35	50	16000	90	7.5	200x600	500	20-60	2	270	3.2t x 3.2t	
	YR-500SB2	50	50	19000	117	9.1	200x600	500	20-60	3	290	3.2t x 3.2t	
	YR-500SA2	50	50	19500	117	8.7	200x600	1000	20-80	3	500	4.0t x 4.0t	
	YR-700SA2	70	50	19500	120	17.0	200x600	1000	20-80	3	510	4.0t x 4.0t	
C	YR-A05SA2	100	50	33000	316	5	200x425	1000	20-80	8	555	5.0t x 5.0t	
	YR-350CM2	Spot	35	50	16000	73	11.5	170x400	500	20-60	2	255	3.2t x 3.2t
		Projection	19500	89	7.7	170x300	—						
	YR-500CM2	Spot	50	50	22500	138	6.6	165x425	1000	20-80	3	500	4.0t x 4.0t
		Projection	29000	178	3.9	165x300	—						
	YR-700CM2	Spot	70	50	22500	138	12.9	165x425	1000	20-80	3	510	4.0t x 4.0t
		Projection	29000	178	7.7	165x300	—						
	YR-A05CM2	Spot	100	50	33000	316	5	165x425	1000	20-80	8	555	5.0t x 5.0t
Projection		40000	384	3.4	165x300	—							

Timer

Micro-Computer Controlled Timer Panatech

YF-0201Z5

- Large LED indication offers better view. (1.5 times compared with our conventional type)
- Has the high accuracy of compensating electrical network voltage function, the output is stable;
- Auto count function can avoid omitting

Standard IC Timer

YF-0701D

Digital Switch Adjustment

Constant current output

Application

- Where constant output current is required
- For single welding condition



MODELS AND RATINGS

	Standard IC Timer	Multi-contin Micro-computer Controlled Timer
Model	YF-0701D	YF-0201Z5
Control	1 condition, 1 step current	4/15 conditions, 2 steps current (4 conditions on delivery)
SOL Signal Output	1 SOL	2 SOL
Compensation Method	Constant current (primary) Compensation for Power source voltage fluctuation	Constant current (primary or secondary) Compensation for Power source voltage fluctuation
Frequency	50/60 changeable	50/60 Auto-charge
Initial Delay Time	Cycle	0-99(15 conditions individually)
Squeeze Time	Cycle	0-99
Weld Time (I)	Cycle	0-99(15 conditions individually)
Up Slope Time	Cycle	0-9(15 conditions individually)
Cooling Time (I)	Cycle	0-99(15 conditions individually)
Weld Time (II)	Cycle	0-99
Down Slope Time	Cycle	0-9(15 conditions individually)
Hold Time	Cycle	0-99(15 conditions individually)
Off Time	Cycle	0-99(15 conditions individually)
Pulsation Times	Cycle	0-9
Range of Current (I) Adjustment (II)	%A	1,500-50,000A (15 conditions individually)
Applicable Welder	Thyristor type Max input up to 150kVA	Thyristor type Max. 5-50kVA
Compensation Accuracy	Within±3% fluctuation with±20% input voltage power fluctuation	within±3% fluctuation with±20% input voltage power fluctuation
Hold Time Finish Signal	Possible with option parts	Built-in
Welding Current Passing Signal	Built-in	Built-in
Inter-Lock Signal	Built-in	Built-in
Change-over Switch	Welding Test, Electrode adjustment	Welding Test, Electrode adjustment
Dimensions(WxDxH)	mm	111x338x308
Weight	kg	4

High function timer with easy operation

Basic setting

